

C18VE Railway Set

Clamshell Bucket / Sleeper & Rail Gripper

Robust grapple with exchangeable tools , with two vertical cylinders for excavators with an operating weight of 13 - 18 t / 28600 - 39000 lbs. With the clamshells with a width of 300 mm ballast can be excavated. The Sleeper & Rail Gripper gets used for re-handling of sleepers and parts of all kinds of rails. All done very effectively – thanks to a quick shell exchange in four minutes.

- An **economic solution** as only the shells have to be exchanged to suit application – bucket carrier, hydraulics and bearings are integrated into the main carrier.
- **Long life** is ensured due to the use of 500 HB steel in the manufacture of cutting edges.
- **Reduced wear** resulting from generously dimensioned bearing system with special coating.
- **Excellent digging characteristics** are the result of **high closing forces (51 kN / 11200 lbf)** at an operating pressure of 35 MPa / 5076 psi).

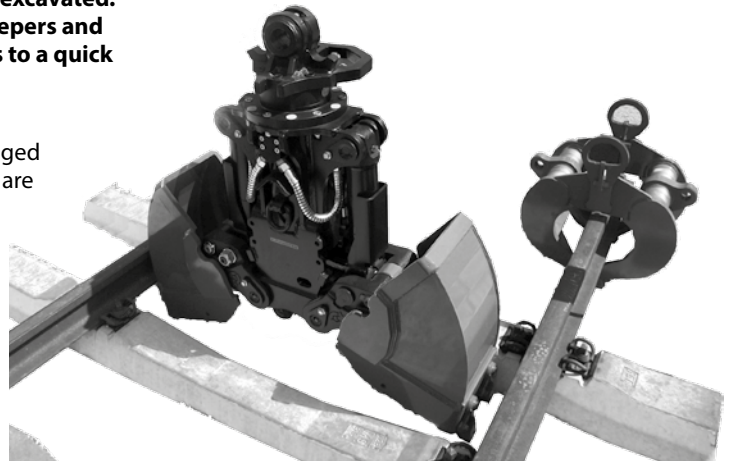

Clamshell Bucket / Sleeper & Rail Gripper C18VE Railway Set

Type	Width E (mm / in)	Opening A (incl. teeth) (mm / in)	Height C max. (incl. teeth) (mm / in)	Length F (mm / in)	Volume (litre / c.y.)	Number of teeth	Self weight (kg / lbs)	Load capacity (kg / lbs)
C18VE + C18VE-30S EG +	300 / 11.81	1310 / 51.57	1470 / 57.84	1145 / 45.08	80 / 0.10	3	535 / 1177	4500 / 9900
C18VE-50S RG	500 / 19.69	1265 / 49.45	1400 / 55.12	760 / 29.92	-	-	515 / 1133	4500 / 9900

Package consists of: Hydraulic main carrier, clamshells with bolt-on teeth, sleeper & rail gripper, **KINSHOFER** rotator, non-return valve and hose guard, 2 welded eyes, exchanging support and extraction tool

KINSHOFER Rotation

Continuous rotation and two oil passages. Overload protection is ensured by pressure relief valves.

Type	Upper connection (width x pin-Ø) (mm / in)	Torque (Nm)	Moment of deflection max. (Nm)
KM 10 F275-60	125 x 60 / 4.92 x 2.36	1500 / 1105	14000 / 10326

Accessories

Type	Description
KM 501 13t-25t	upper suspension without pendulum damper
KM 511 13t-25t	upper suspension with pendulum damper
SW10 cardanic	adapter for Lehnhoff grab exchange system SW/MS10 without suspension – up to 19t / 41800 lbs
SW21 cardanic	adapter for Lehnhoff grab exchange system SW/MS21 without suspension – up to 28t / 61600 lbs
	adapter for quick exchange systems from other manufacturers available
KM 680 C12VE/C18VE	scraper

Requirements of Excavator

Operating pressure (open/close):	max. 35 MPa (350 bar) / 5076 psi
Pump capacity (open/close):	75 - 150 l/min / 19.82 - 39.63 GPM
Operating pressure (rotation):	max. 32 MPa (320 bar) / 4608 psi
Pump capacity (rotation):	25 - 75 l/min / 6.61 - 19.82 GPM

Technical Designs

